

# ASSEMBLY INSTRUCTION

DESCRIPTION:  
CAT. NO PNQQ4  
BELLAGIO GB I  
2+2 DRW CHEST

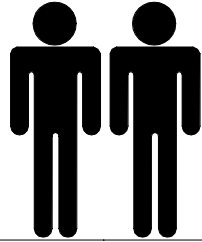

2 PERSON ASSEMBLY

FLOOR AREA  
3.5M X 2.0M



CEILING HEIGHT  
2.3M

(FLAT BULD)  
REQUIRED ASSEMBLY SPACE

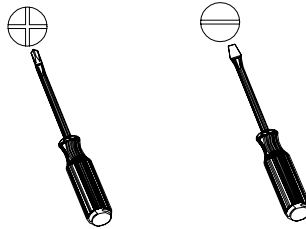

REQUIRED ASSEMBLY TOOLS

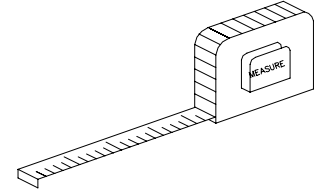

ASSEMBLED DIMENSIONS

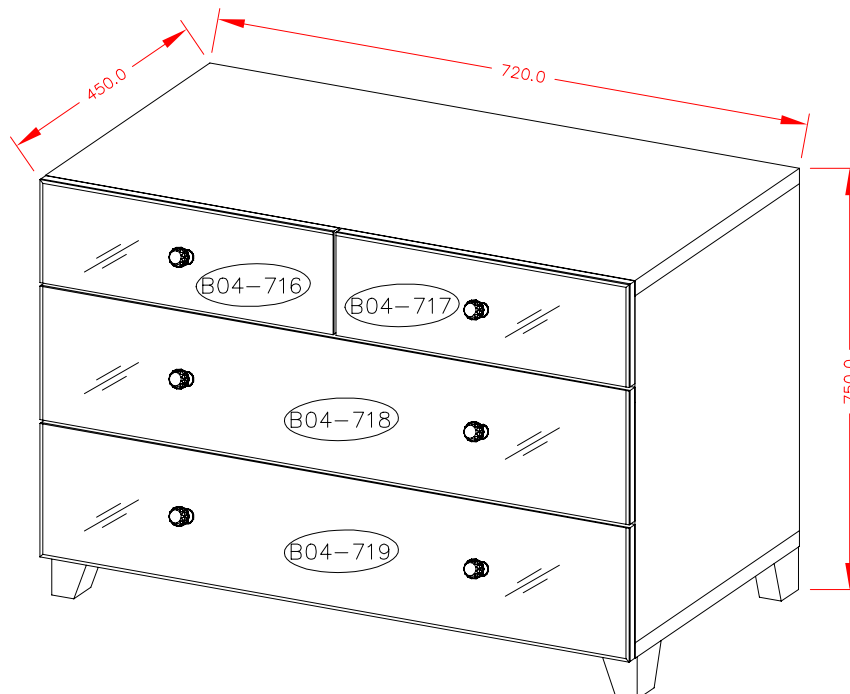

SKYWAYS HOUSE, SPEKE ROAD, LIVERPOOL L70 1AB

PARTS LIST

BOTTOM WREATH



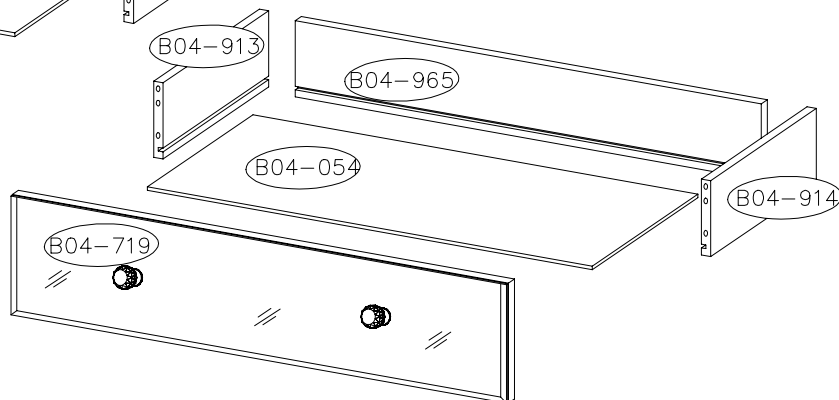
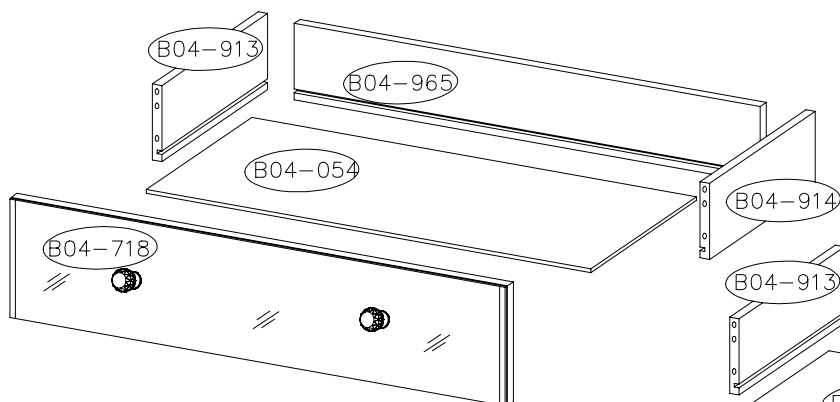
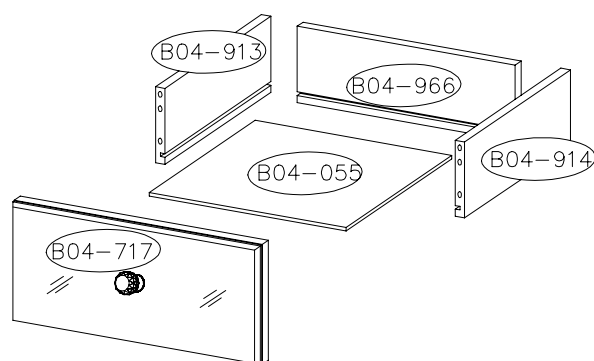
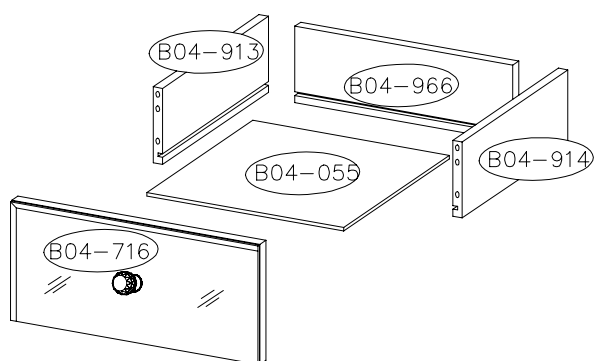
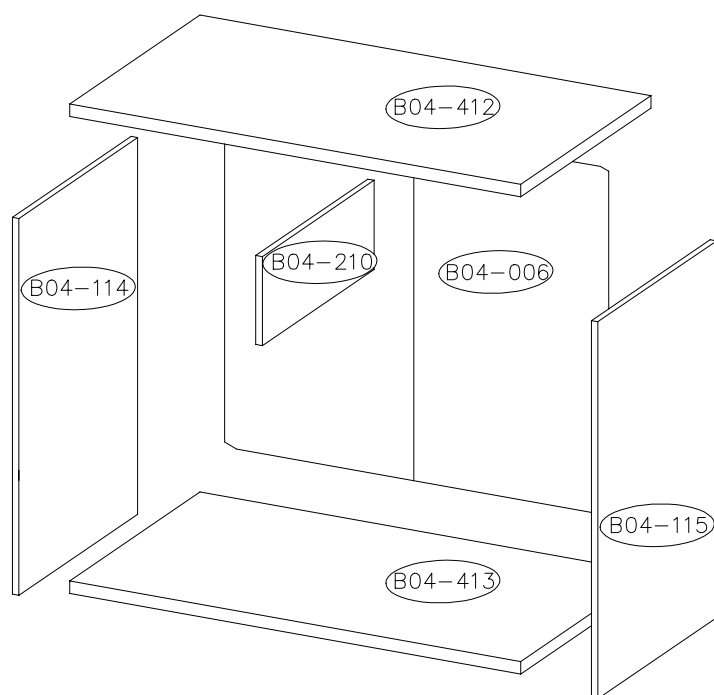





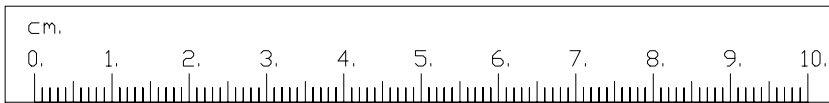
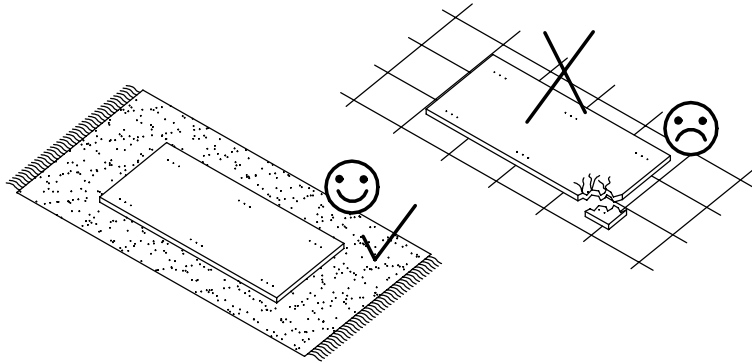
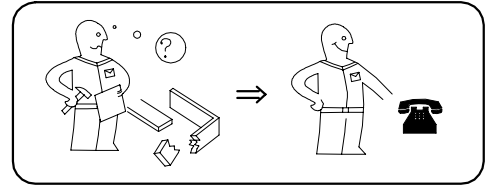
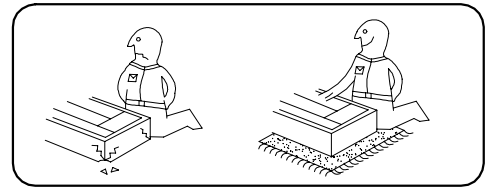
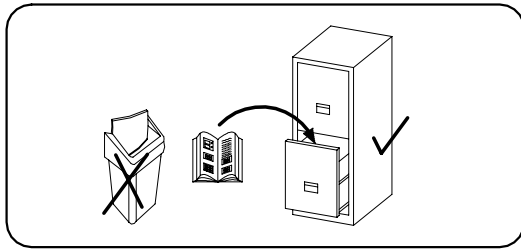







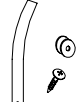
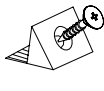

NO.	PART LIST	QTY
114	LEFT SIDE	1
115	RIGHT SIDE	1
210	DASH PANEL	1
412	TOP PANEL	1
413	BOTTOM PANEL	1
716	DRAWER'S FRONT	1
717	DRAWER'S FRONT	1
718	DRAWER'S FRONT	1
719	DRAWER'S FRONT	1
913	LEFT SIDE OF CARCASE	4
914	RIGHT SIDE OF CARCASE	4
965	BACK PANEL OF CARCASE	2
966	BACK PANEL OF CARCASE	2
054	BOTTOM OF DRAWER	2
055	BOTTOM OF DRAWER	2
006	BACK PANEL	1

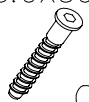
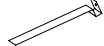

PACK 1 CONSISTS OF PARTS:

114, 115, 210, 412, 413, 716, 717, 718, 719, 913, 914, 965, 966, 054, 055, 006, Al, Fittings

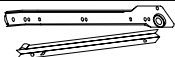

 A	 B	 C	 D	5.0X13  F10	6.0X11  F1	M4.0X20  G	 I1	 J	4mm  K
14	12	8	26	4	16	6	1	8	1
3mm  M	 P	3.0X13  P2	3.0X20  P4	3.5X13  S	6.4X50  V	 U	5.0X50  Q	 Z	
1	4	8	16	10	4	6	24	2	
	 B1					 R			
						 L			
	2					4 KPL			

## **Top Tips before you start!**

1. Please check that all parts are present before you start the assembly of your furniture, as once assembled, the furniture is exempt from our home approval policy.
2. For ease and speed of assembly, we recommend that before you commence each step of the assembly, that you identify all the parts required for that step.
3. For larger items, please ensure that you have sufficient space and people ( as indicated on page 1 ) to assemble your product safely.
4. We recommend that, where possible, all items are assembled near to the area in which they will be placed in use, to avoid moving the product unnecessarily once assembled.
5. For the protection of your furniture, particularly items of high gloss finish, we recommend that the product is placed on a protected surface during assembly to prevent any damage.
6. During assembly please take care not to over-tighten any fittings, as this may damage the product.

## **Care and Maintenance of your Furniture**

Please periodically check all fittings and re-tighten as necessary.

To clean your item, please use a damp cloth and wipe clean.

Never allow any kind of liquid to remain on your furniture. Absorption can cause wood to warp or finishes to de-laminate.





Please do not place hot items ( e. g. hot drinks ) directly on to the wood surface.

Please do not drag or pull your furniture.





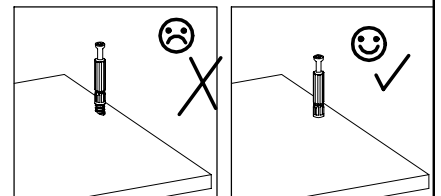
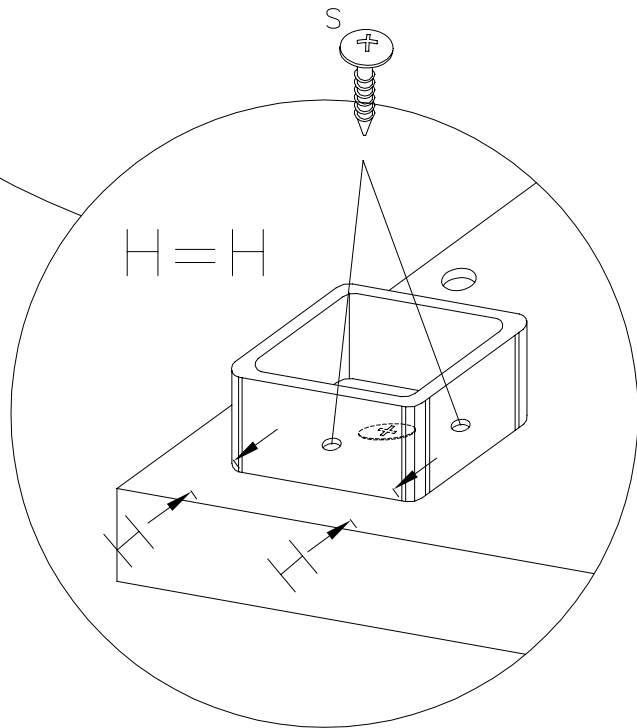
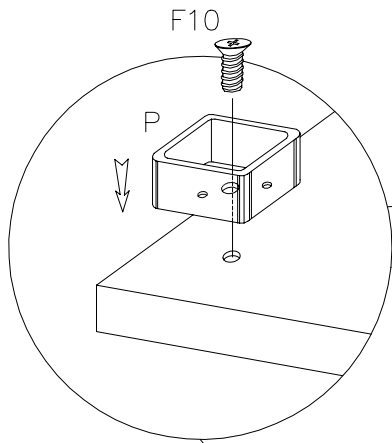
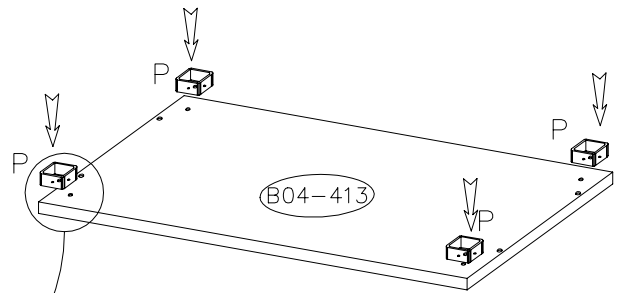
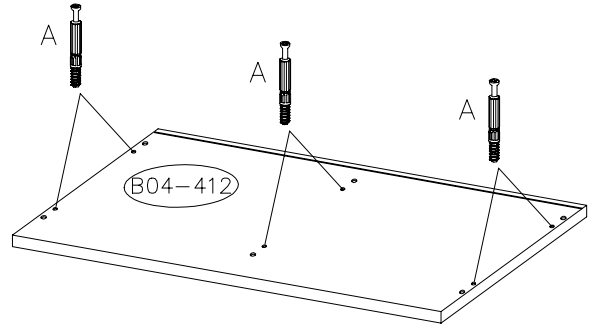

# **WARNING! IN ORDER TO HELP PREVENT OVERTURNING THIS PRODUCT MUST BE USED WITH THE WALL ATTACHMENT DEVICE PROVIDED**

## **Free Standing Furniture with a height over 600mm**





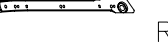

- Use the wall attachment device provided
- Never allow children to climb or hang on drawers, doors or shelves.
- Place heaviest items in the lower drawers or shelves
- Unless specifically designed to accommodate, do not set TV's or other heavy objects on top of this product.
- Never open more than one drawer at a time.

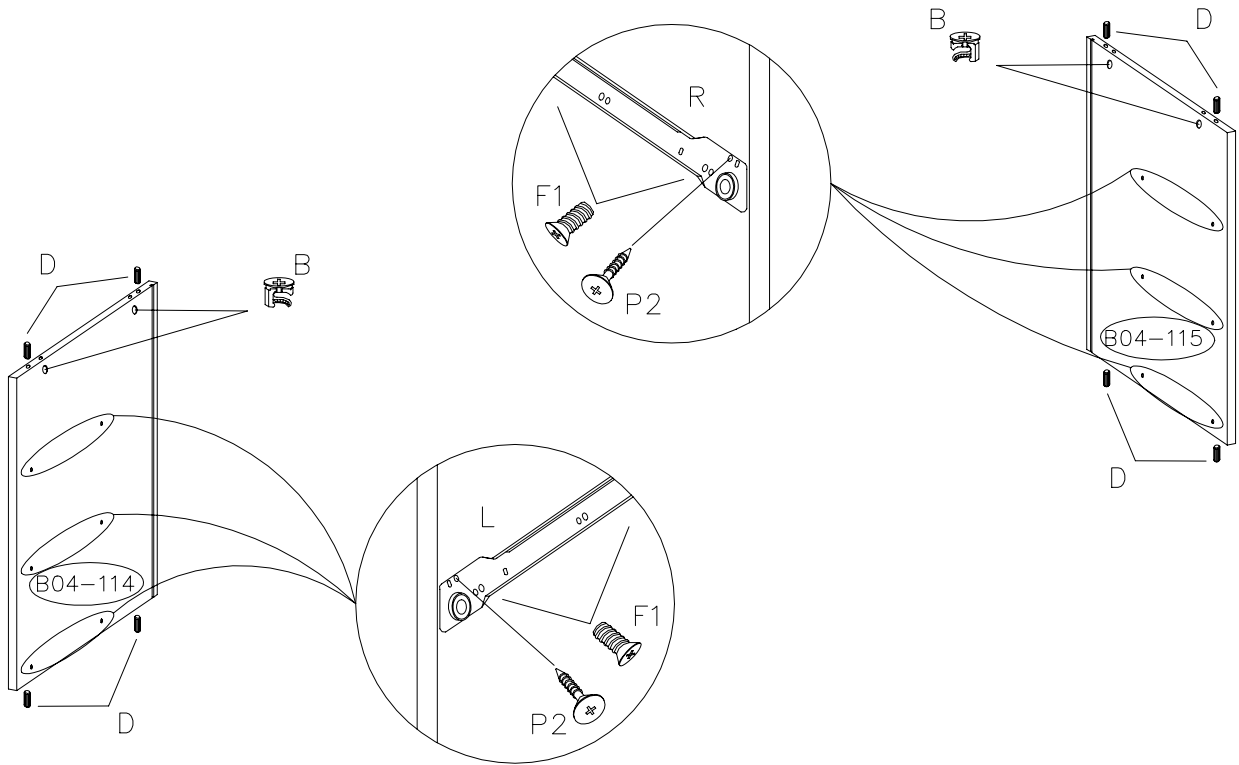
 A	5.0X13  F10	 P	3.5X13  S
6	4	4	8



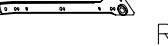

		6.0X11 	3.0X13 	 R  L
4	8	12	6	3



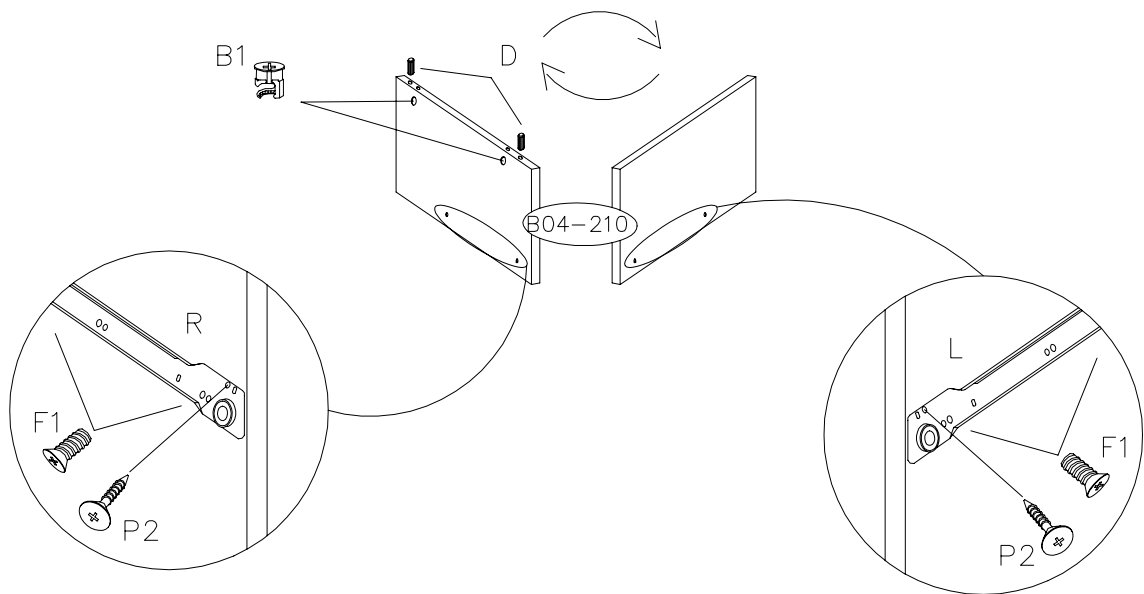

		6.0X11 	3.0X13 	 R  L
2	2	4	2	1

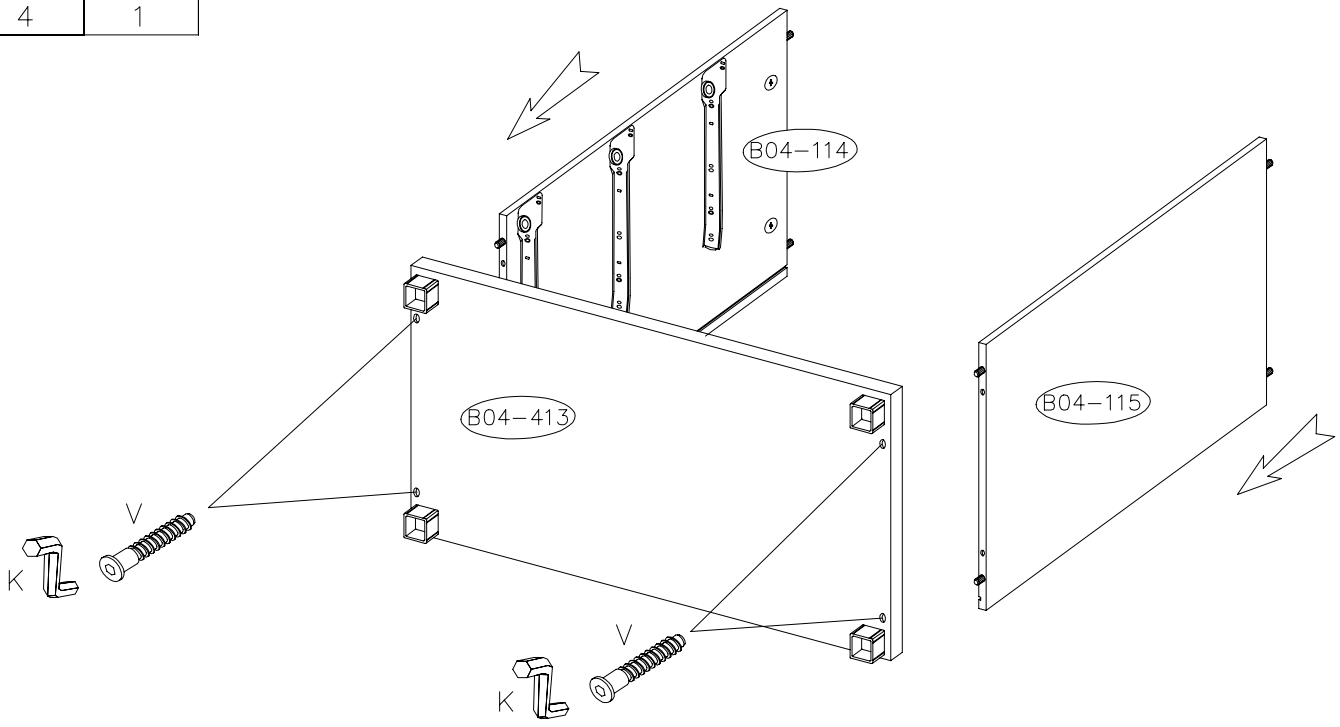

6.4X50  V	4mm  K
4	1

4







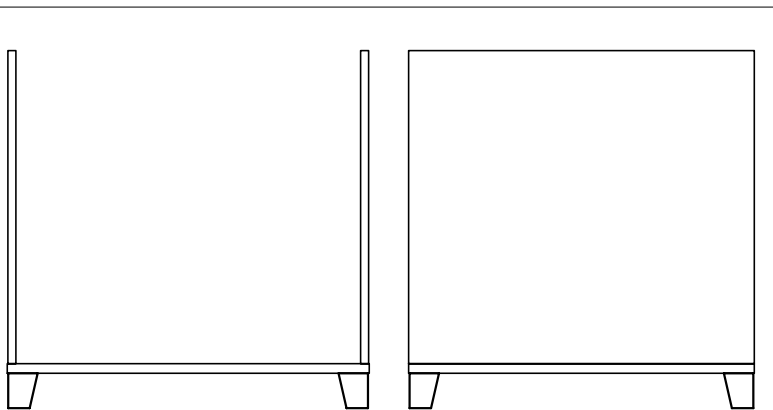
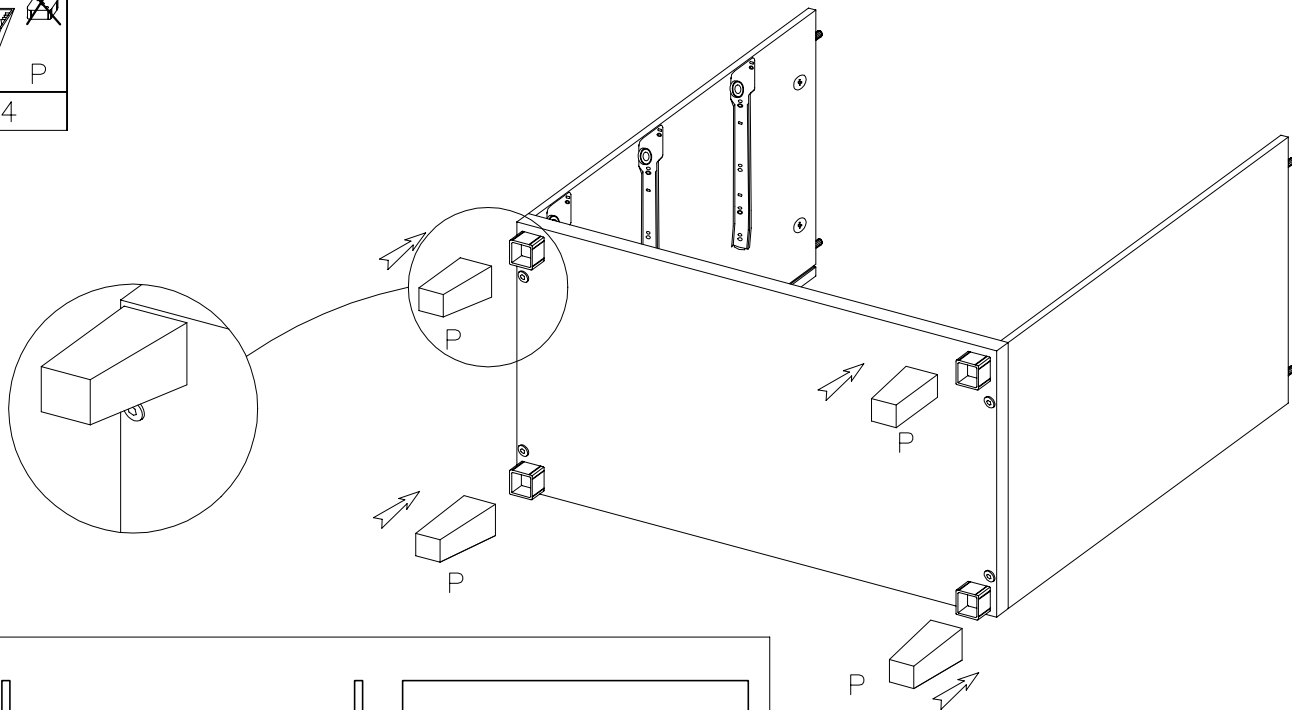

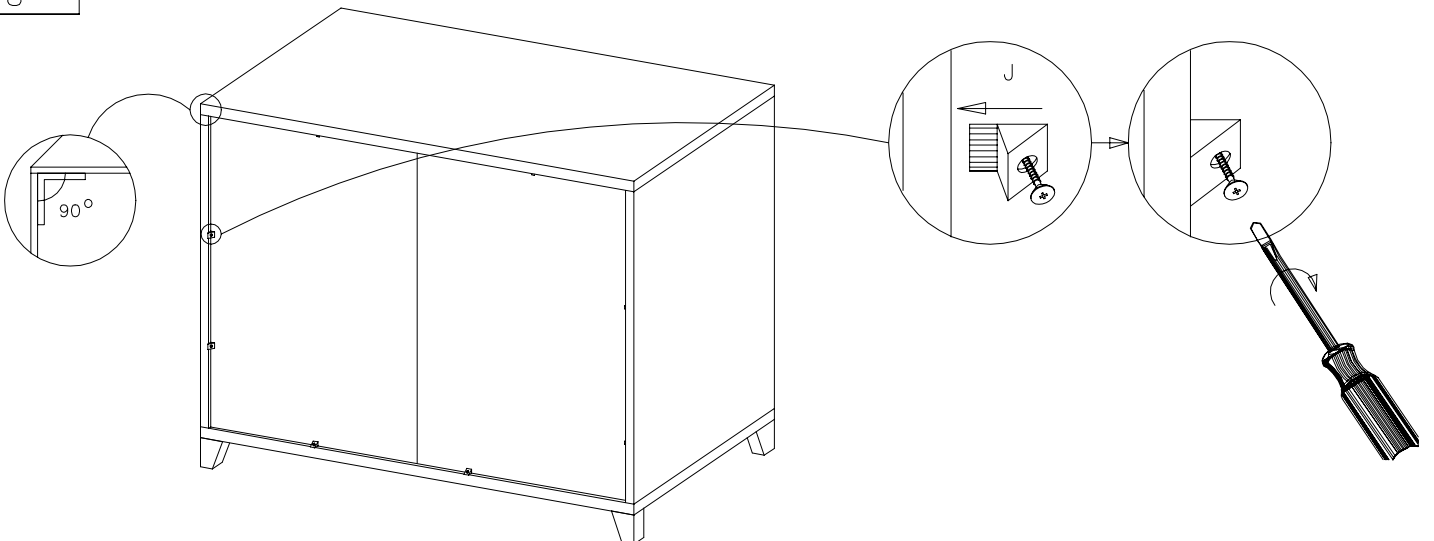
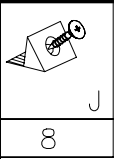
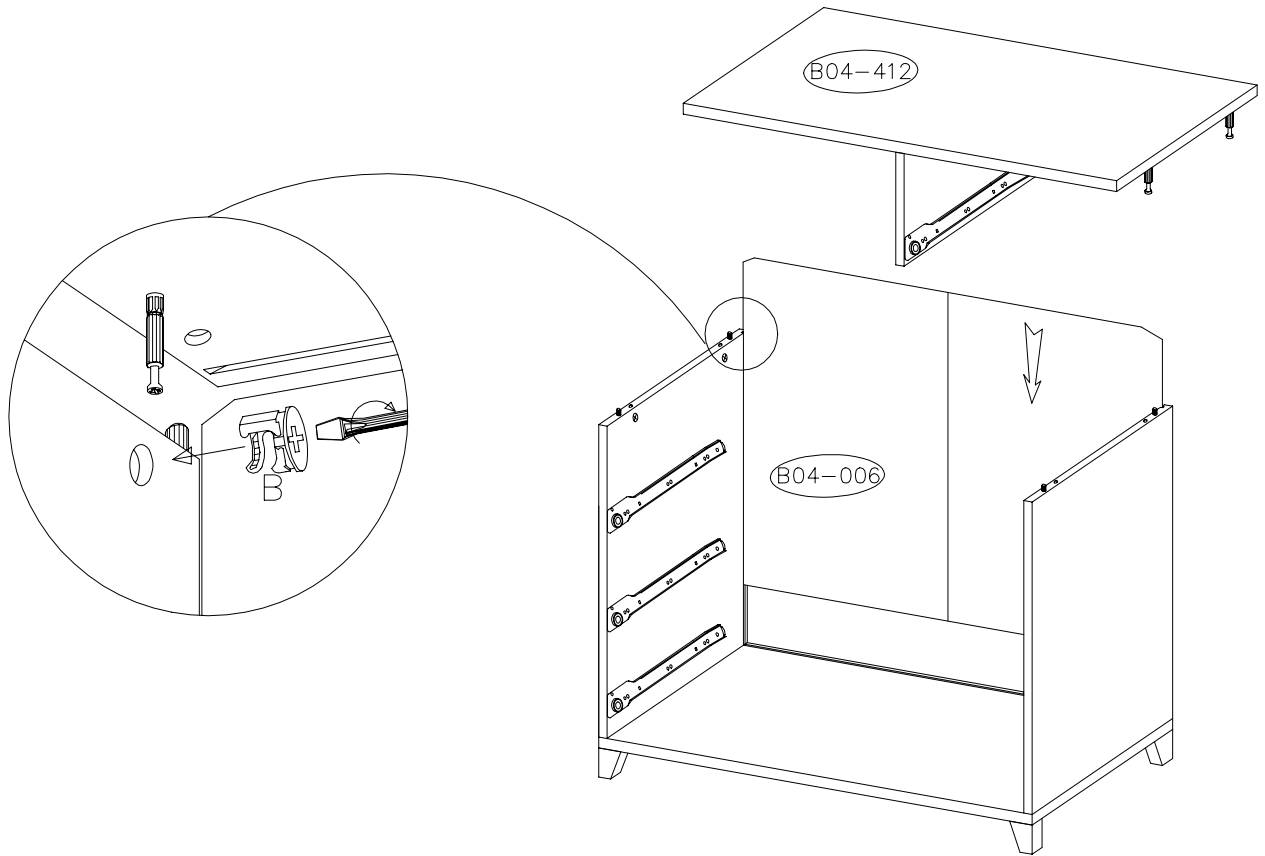
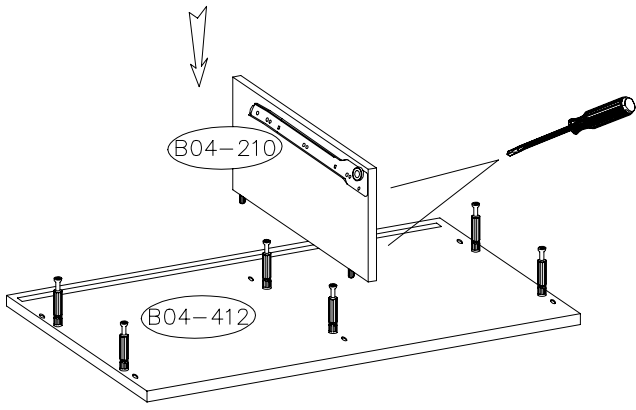

 P
4

5









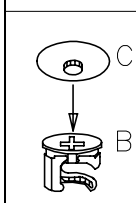
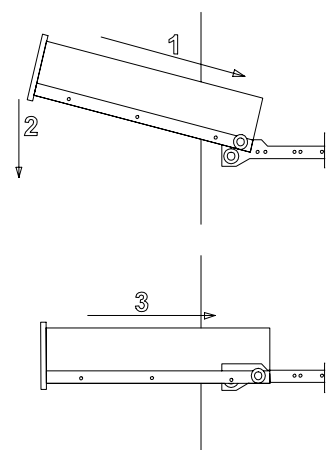
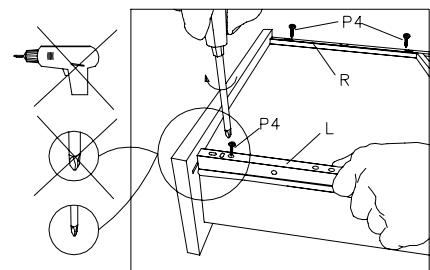
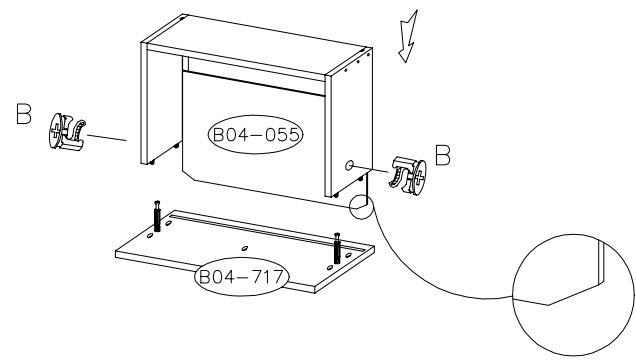
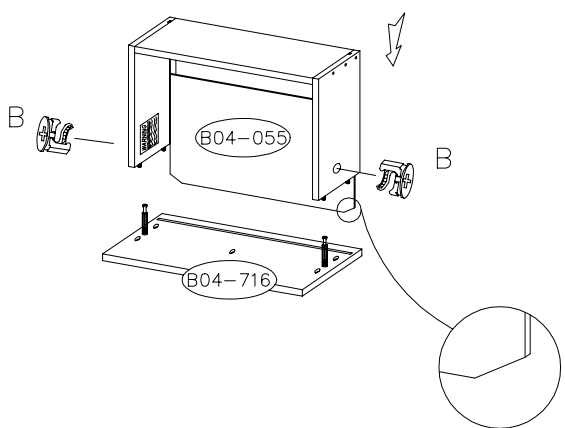
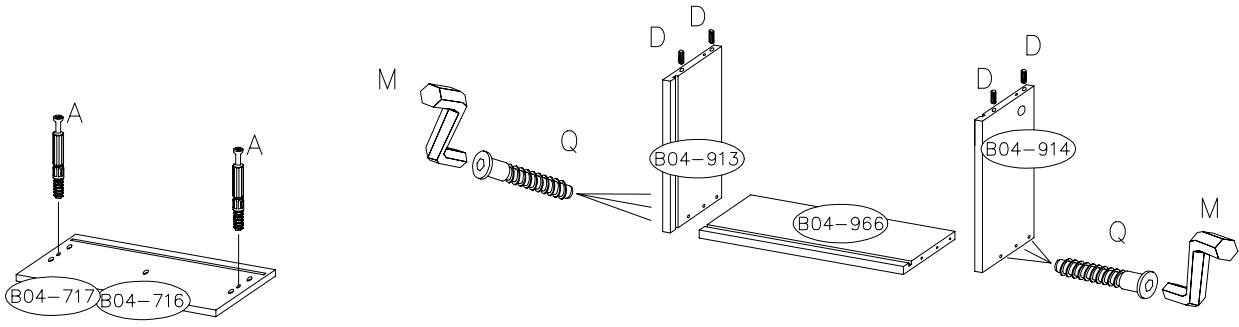
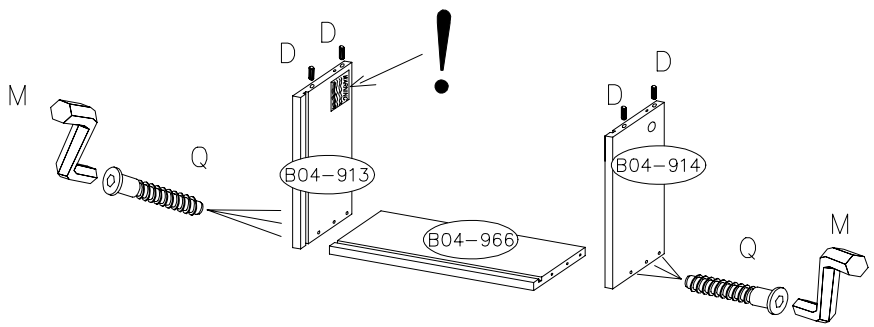









 A	 B	 C	 D	3mm  M	3.0X20  P4	5.0X50  Q	 R	
4	4	4	8	1	8	12	 L	

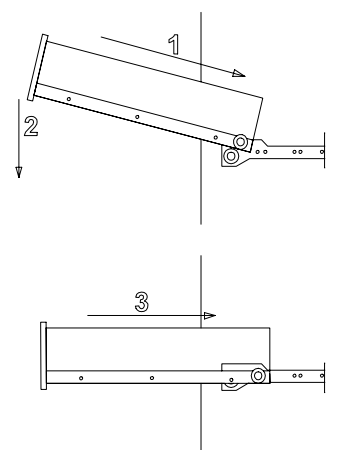
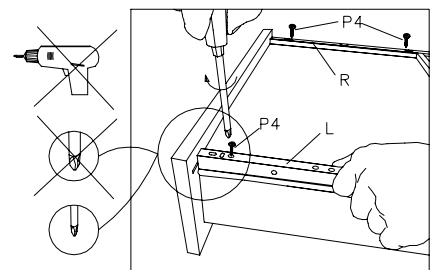
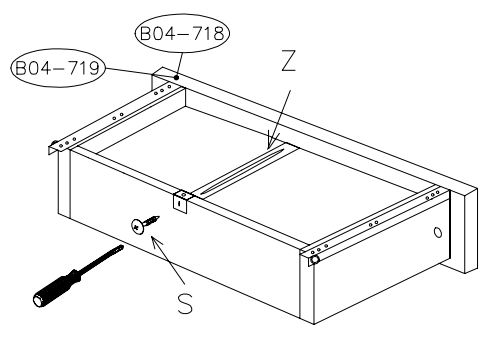
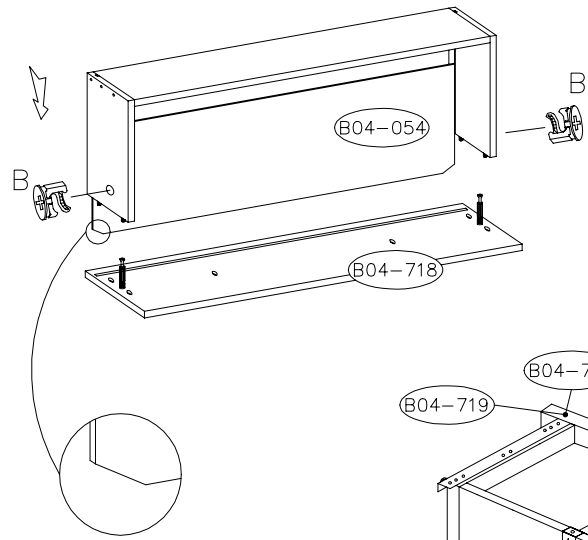
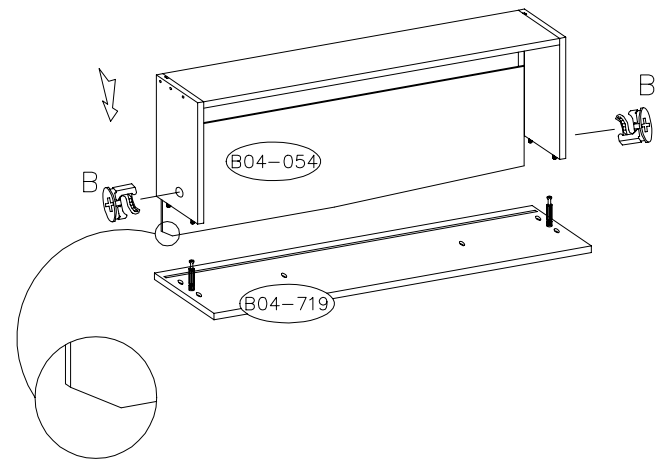
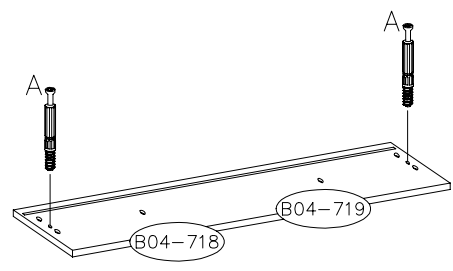
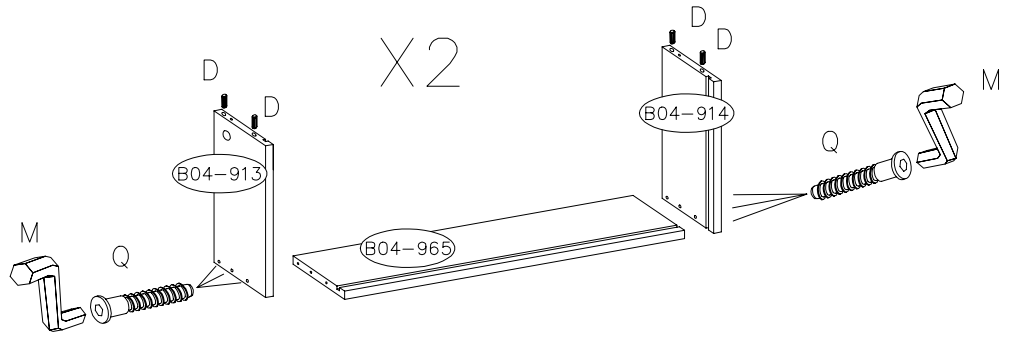

 A	 B	 C	 D	3mm  M	3.0X20  P4	3.5X13  S	 Z	5.0X50  Q	 R  L
4	4	4	8	1	8	2	2	12	2



M4.0X20		
	G	U
6		6

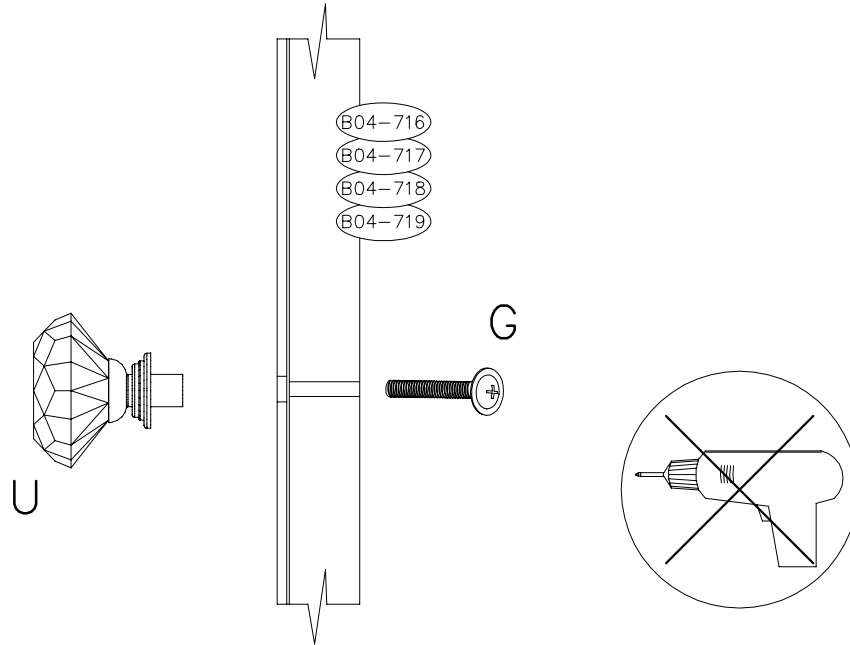

**CAUTION:** Only hand tighten the handle, overtightening could damage the mirrored drawer fronts.

For Missing / Damaged Spare parts - please visit the website

- My Account
- Account Queries
- Contact US!

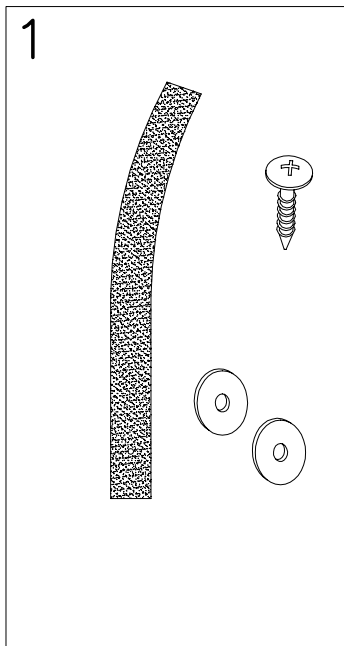

⚠	<b>Uwaga • Upozornini • Achtung • Attention • Caution • Figyelem • Attenzione • Opgelet • Внимание • Atentie • Upozornenie • Dikkat</b> ⚠
PL	Mocowanie do ściany jest jednocześnie zabezpieczeniem przed przewróceniem – koniecznie zamontować!
CZ	Do některých druhů stěn koniečně zastosować specjalne kołki mocujące. Montaż na ścianę służy jako ochrona proti převrnutí! – bezpodmienečně umístěte! U některých typů stěn může být zapotřebí speciální hmoždinka!
D	Wandbefestigung dient als Kippschutz – unbedingt anbringen! Bei einigen Wandtypen kann ein Spezialdübel erforderlich sein!
GB	The wall fastening serves to prevent tipping – be absolutely sure to mount it! For certain wall types, a special wall plug may be necessary!
FR	La fixation murale sert de protection contre le basculement – à installer impérativement ! Pour certains types de murs il faut des chevilles spéciales !
NL	Bevestiging aan de muur dient als kantelbescherming – zeker en vast bevestigen! Bij enkele muurtypes is een speciale plug misschien vereist!
IT	Il fissaggio alla parete serve da protezione anti-ribaltamento – attaccarla assolutamente! Per alcune strutture di parete può essere necessario un tassello speciale!
HU	A termékét a falhoz kel rögzíténi, különben az felborulhat! Egyes faltípusoknál speciális tiplít kell használni!
RU	Обязательно установите крепление на стене во избежание опрокидывания! Для некоторых типов стен может потребо- ваться специальный дюбель!
RO	Sistemul de fixare la perete servește ca protecție la răsturnare – de montat obligatoriu! Pentru unele tipuri de pereți este posibil să fie necesar un diblu special!
SK	Upevnenie na stenu slúži ako ochrana proti prevráteniu – bezpodmienečne použite! Pre niektoré druhy stien môže byť potrebná špeciálna hmoždinka!
TR	Duvardaki sabitleme, devrilmeye karşı bir emniyet tedbiridir ve mutlaka monte edilmelidir! Bazı duvar tiplerinde bunun için özel bir dübel gerekli olabilir!

